

**NOTE:**

- 1.Application of span  $\leq 200M$ .
- 2.Range of diameter of cable dia.:12.7-13.5mm.
- 3.Grip strength: $\geq 14\%$ RTS.
- 4.All ferrous parts are hot-dip galvanized.
- 5.All dimensions are in millimeters.

4	1	OPEN EYE SPIRAL BOLT	GEAP-16/350	GALV.STEEL
3	1	SUSPENSION RING	XH-2	GALV.STEEL
2	1	OUTER SUSPENSION RODS	AXY 1300 200-W	AL CLAD STEEL
1	1	INNER SUSPENSION RODS	AXY 1300 200-N	AL CLAD STEEL
ITEM	QTY	DESCRIPTION	TYPE	MATERIAL

Tolerance		ADSS Suspension clamps TYPE:AXY 1300 200						
$\leq 30mm$	$\pm 1.5mm$				DRAWING	L.Z.G	DATE:2020-03-05	
$> 30mm$	$\pm 5\%$	VERIFY	ZHJ	DRAWING NO.				Version
MAX.	$\pm 10mm$			RATIFICATION				ZHJ

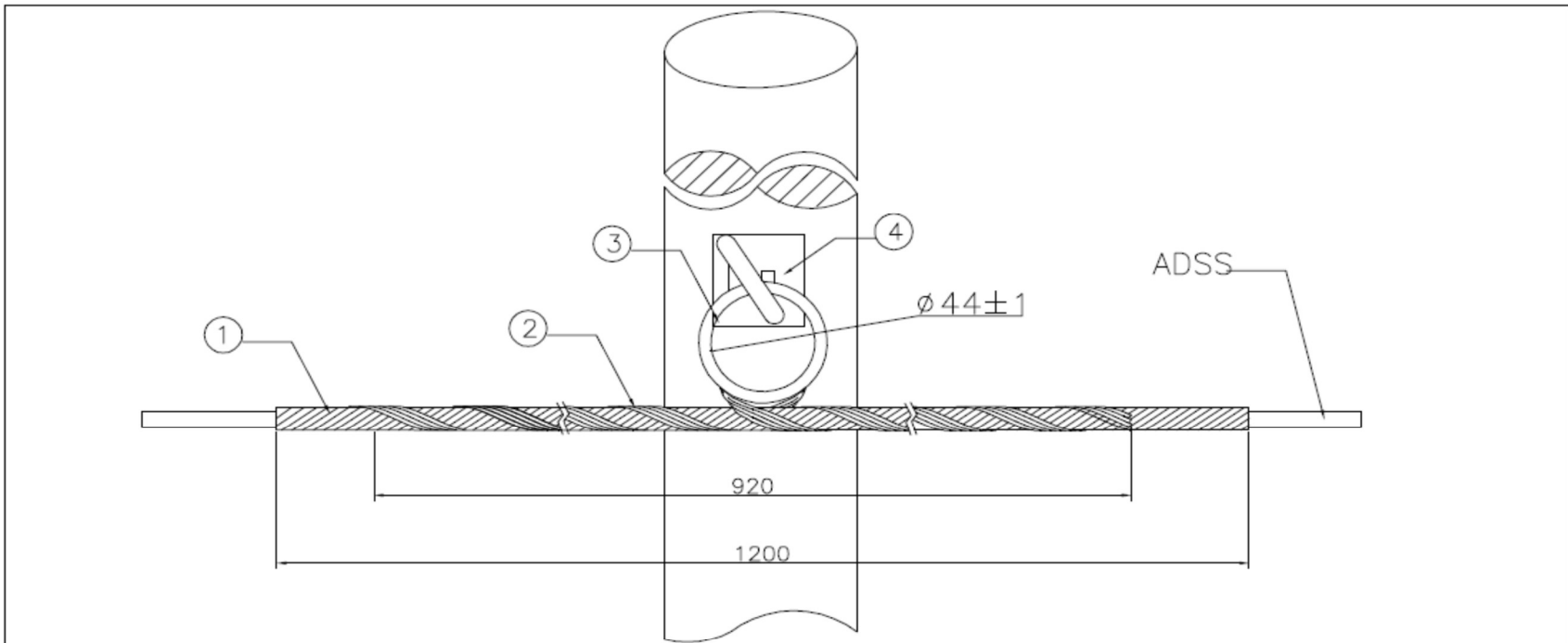

NOTE:

- 1.Application of span ≤ 200M.
- 2.Range of diameter of cable dia.: 13.0-13.9mm.
- 3.Grip strength: ≥ 14%RTS.
- 4.All ferrous parts are hot-dip galvanized.
- 5.All dimensions are in millimeters.

4	1	HELIX HOOK	GEAP-16/350	GALV.STEEL
3	1	SUSPENSION RING	XH-2	GALV.STEEL
2	1	OUTER SUSPENSION RODS	AXY 1400 200-W	AL CLAD STEEL
1	1	INNER SUSPENSION RODS	AXY 1400 200-N	AL CLAD STEEL
ITEM	QTY	DESCRIPTION	TYPE	MATERIAL

Tolerance		ADSS Suspension clamps TYPE:AXY 1400 200			
≤30mm	±1.5mm				
>30mm	+5%				
MAX.	±10mm				
DRAWING		L.Z.G	DATE:2020-04-23	DRAWING NO.	Version
VERIFY		ZHJ		AXY 1400 200-01	<b>A</b>
RATIFICATION		ZHJ			

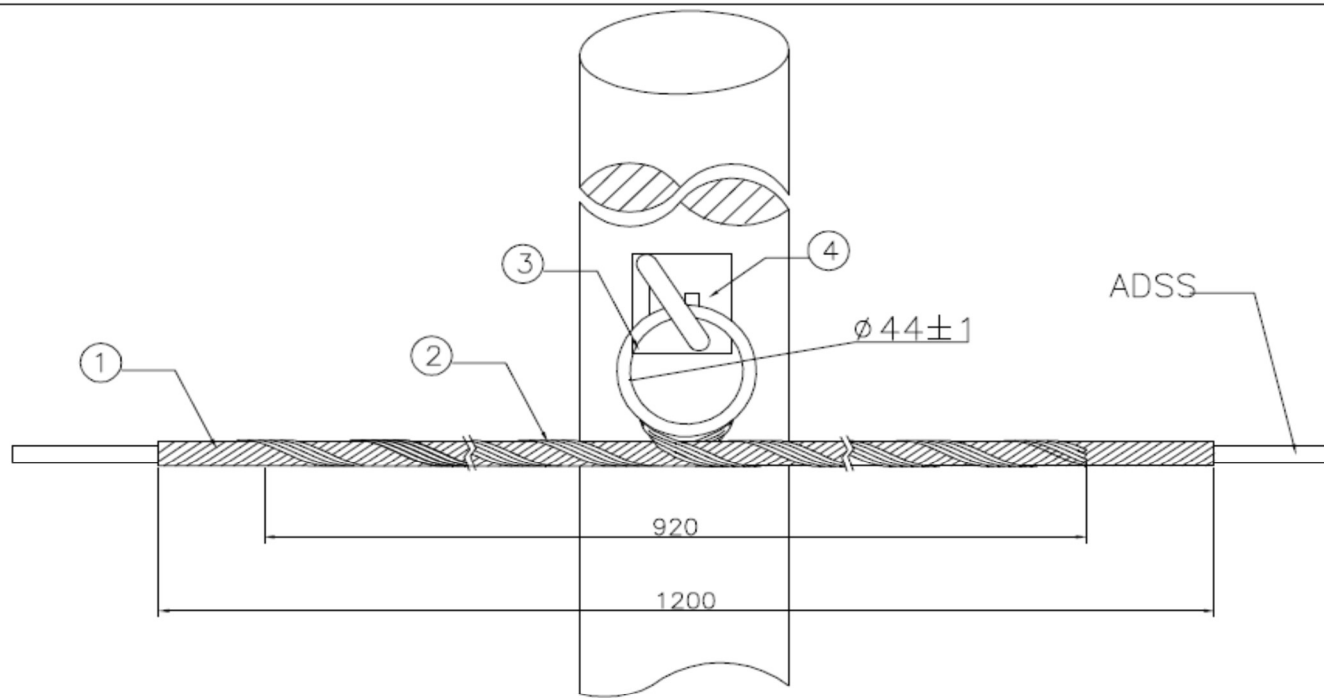

NOTE:

- 1.Application of span ≤ 200M.
- 2.Range of diameter of cable dia.: 17.0-17.9mm.
- 3.Grip strength: ≥ 14%RTS.
- 4.All ferrous parts are hot-dip galvanized.
- 5.All dimensions are in millimeters.

ITEM	QTY	DESCRIPTION	TYPE	MATERIAL
4	1	HELIX HOOK	GEAP-16/350	GALV.STEEL
3	1	SUSPENSION RING	XH-2	GALV.STEEL
2	1	OUTER SUSPENSION RODS	AXY 1800 200-W	AL CLAD STEEL
1	1	INNER SUSPENSION RODS	AXY 1800 200-N	AL CLAD STEEL

Tolerance		ADSS Suspension clamps TYPE:AXY 1800 200			
≤30mm	±1.5mm				
>30mm	±5%				
MAX.	±10mm				
DRAWING		L.Z.G	DATE:2020-04-23	DRAWING NO. AXY 1800 200-01	Version <b>A</b>
VERIFY		ZHJ			
RATIFICATION		ZHJ			

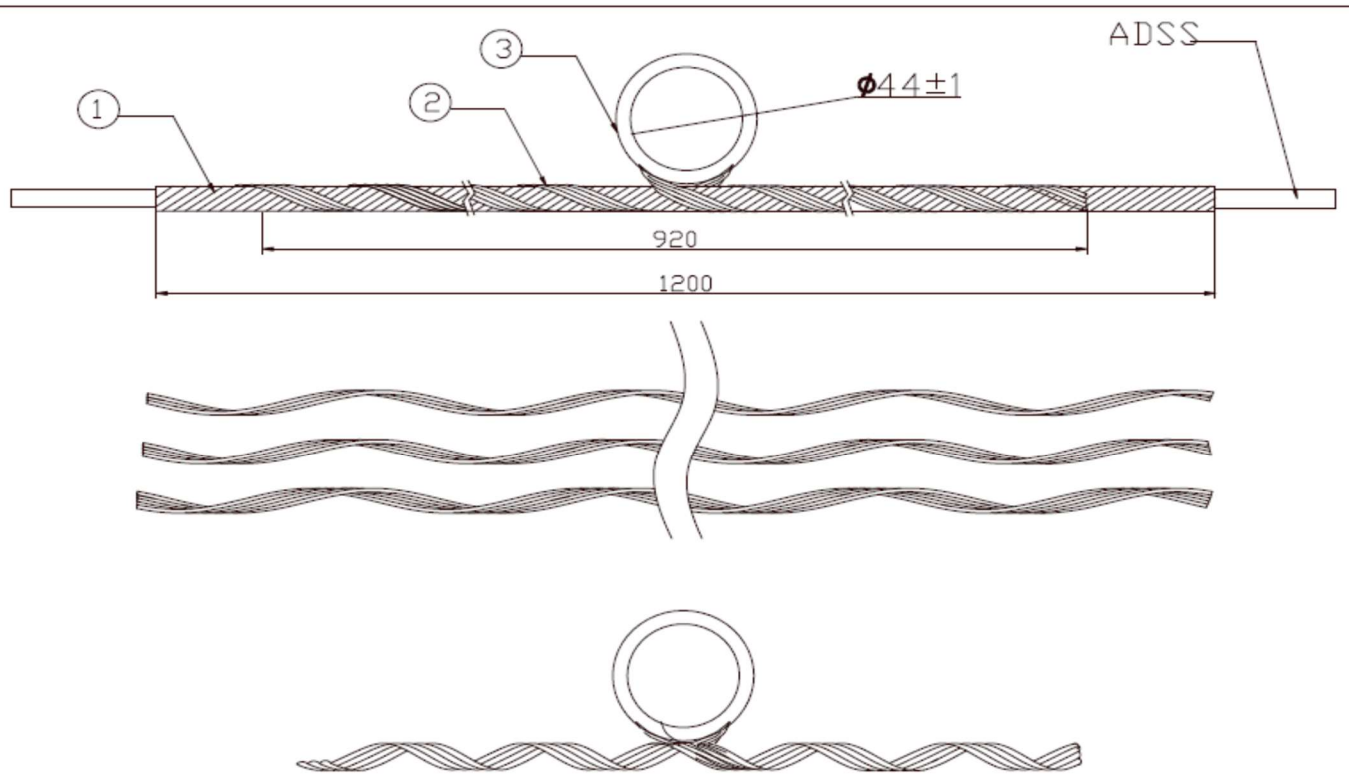

- NOTE:**
1. Application of span  $\leq 200M$ .
  2. Range of diameter of cable dia.: 12.7-13.5mm.
  3. Grip strength:  $\geq 14\%RTS$ .
  4. All dimensions are in millimeters.
  5. The Material of Suspension Rods: AL CLAD STEEL.

<b>Tolerance</b>		<b>ADSS Suspension clamps TYPE:AXY 1300 200</b>		
$\leq 30mm$	$\pm 1.5mm$			
$> 30mm$	$\pm 5\%$	DATE:2020-03-05		
MAX.	$\pm 10mm$			
<b>DRAWING</b>	L.Z.G			
<b>VERIFY</b>	ZHJ	AXY 1300 200-01	<b>A</b>	
<b>RATIFICATION</b>	ZHJ			

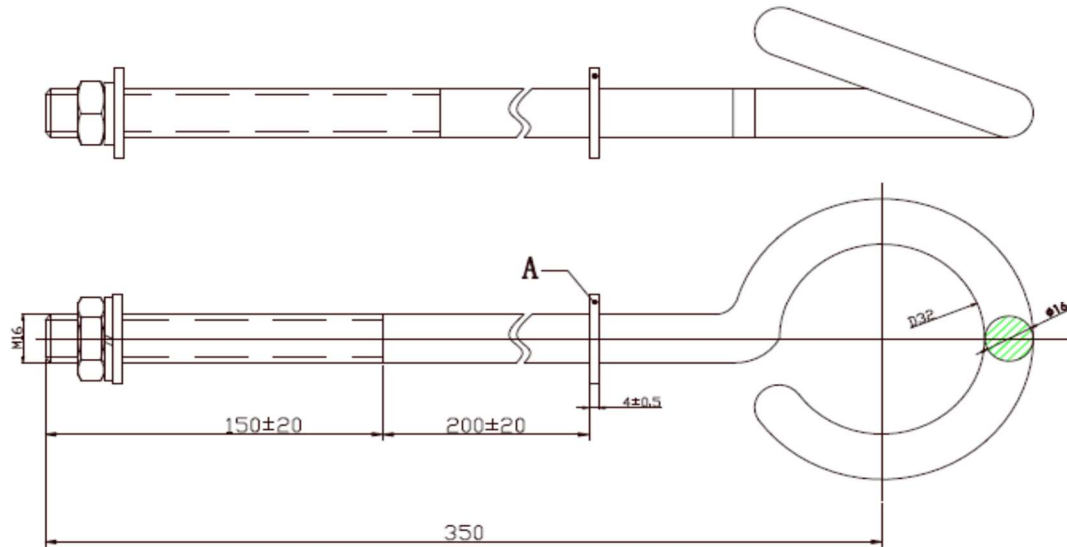

**NOTE:**  
 1. Hot dip galvanized surface treatment.  
 2. Each set with one nut M16 & one flat washer & one Spring washers.

<b>Tolerance</b>			<b>OPEN EYE SPIRAL BOLT TYPE:GEAP-16/350</b>		
≤30mm	±1.5mm				
>30mm	±5%				
MAX.	±10mm				
<b>DRAWING</b>	<b>L.Z.G</b>	<b>DATE:2020-03-05</b>	<b>DRAWING NO.</b>	<b>Version</b>	
<b>VERIFY</b>	<b>ZHJ</b>		<b>GEAP-16/350</b>	<b>A</b>	
<b>RATIFICATION</b>	<b>ZHJ</b>				

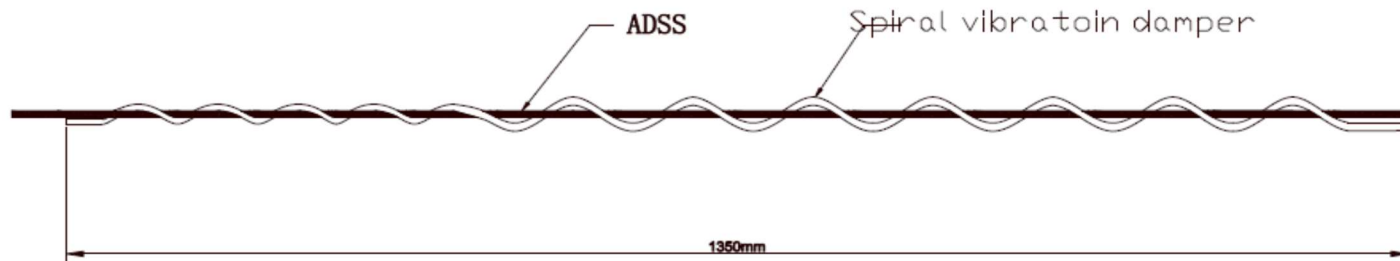

**NOTE:**

- 1.To ensure for diameter of cable from 11.71 to 14.3 millimetre .
- 2.High-elasticity PVC plastic, nonmetallic.
- 3.All dimensions are in millimeters.

<b>Tolerance</b>		<b>Spiral vibration damper TYPE:AFZ 135 143</b>		
≤30mm	±1.5mm			
>30mm	±5%			
MAX.	±10mm			
<b>DRAWING</b>	<b>L.Z.G</b>	DATE:2020-03-05	<b>DRAWING NO.</b>	<b>Version</b>
<b>VERIFY</b>	<b>ZHJ</b>		AFZ 135 143	<b>A</b>
<b>RATIFICATION</b>	<b>ZHJ</b>			

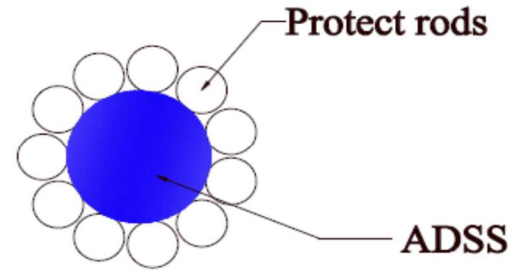
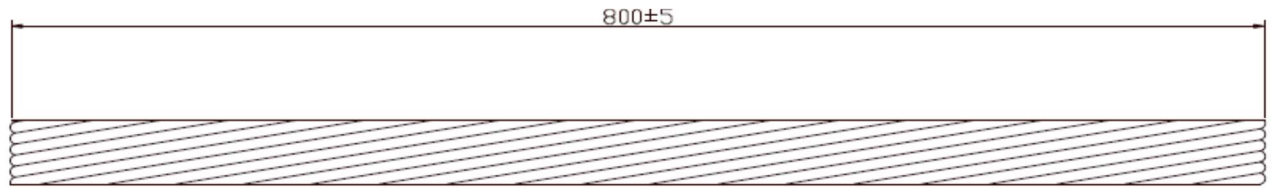

HXT-800	3.5	800	13
Type	d	L	rod/set

**NOTE:**

1. Range of diameter cable: 12.7-13.5mm.
2. Material: Aluminium alloy.
3. All dimensions are in millimeters.

<b>Tolerance</b>		<b>Armour rods TYPE:HXT-800</b>		
≤30mm	±1.5mm			
>30mm	±5%			
MAX.	±10mm			
DRAWING	L.Z.G	DATE:2020-03-05	DRAWING NO.	Version
VERIFY	ZHJ		HXT-800	A
RATIFICATION	ZHJ			

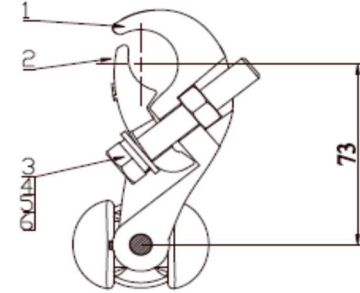
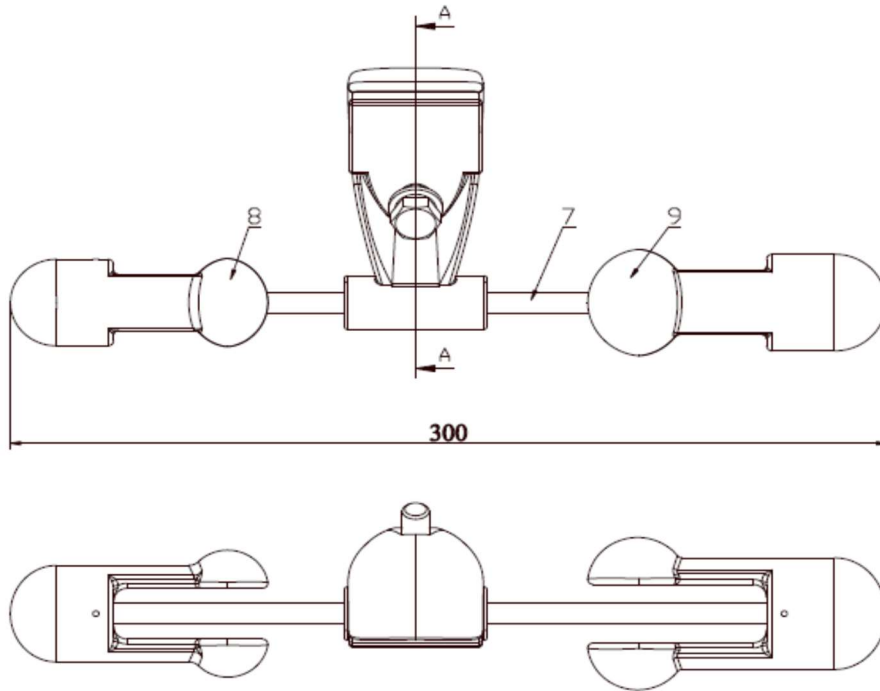

ITEM	DESCRIPTION	QTY	MATERIAL
8, 9	DAMPER	2	GALV. CAST IRON
7	MESSENGER CABLE	1	GALV. STEEL
6	SPRING WASHER	1	GALV. STEEL
5	PLAIN WASHER	1	GALV. STEEL
4	NUT	1	GALV. STEEL
3	BOLT	1	GALV. STEEL
2	KEEPER	1	AL ALLOY
1	CLAMP HOOK	1	AL ALLOY

**NOTE:**  
All dimensions are in millimeters.

Tolerance		Vibration damper for ADSS TYPE:4D-20		
≤30mm	±1.5mm			
>30mm	±5%			
MAX.	±10mm			
DRAWING	L.Z.G	DATE:2020-03-05	DRAWING NO.	Version
VERIFY	ZHJ		4D-20	A
RATIFICATION	ZHJ			



