



FROG ENGINEERING

IP65 H-41U 800x800



FROG ENGINEERING



FROG ENGINEERING

IP65 H-41U 800x800



Technical Drawing

Features

19" Compatibility
IP65 Protection
Double Door
LED
Earthing Bar
PDU, DIN Rail

Dimensions

Size : 41U
Width : 800 mm
Height : 2100 mm
Depth : 800 mm

Material

1.5 mm Steel

Appearance

Finish Surface : Powder Coating
Color : RAL7035



FROG ENGINEERING

IP65 H-41U 800x800

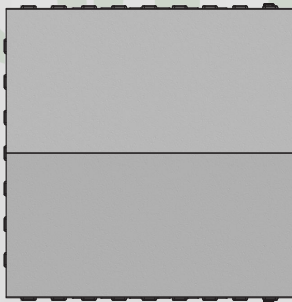
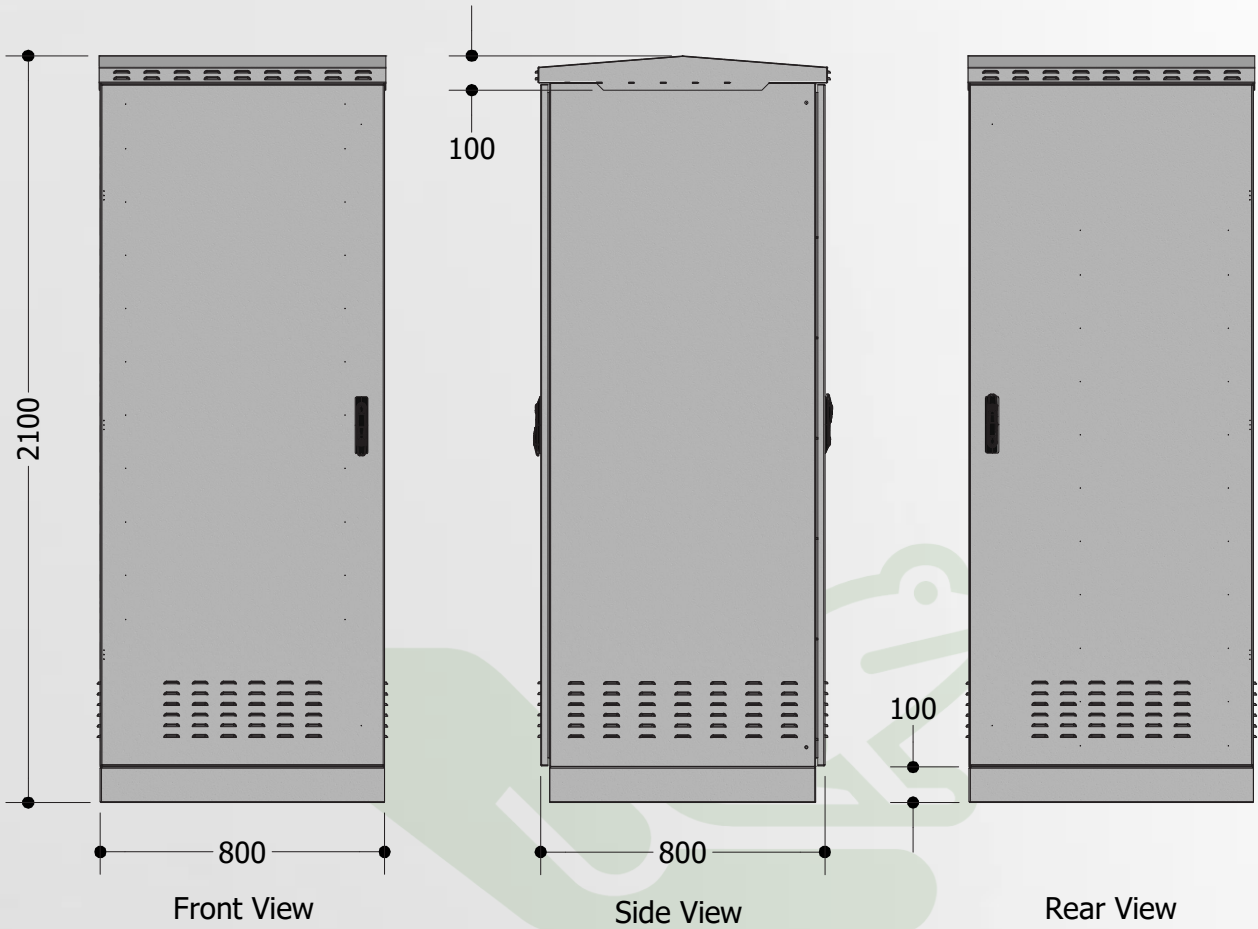

Top View

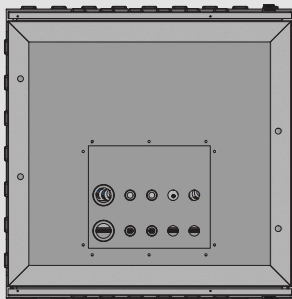

Bottom View

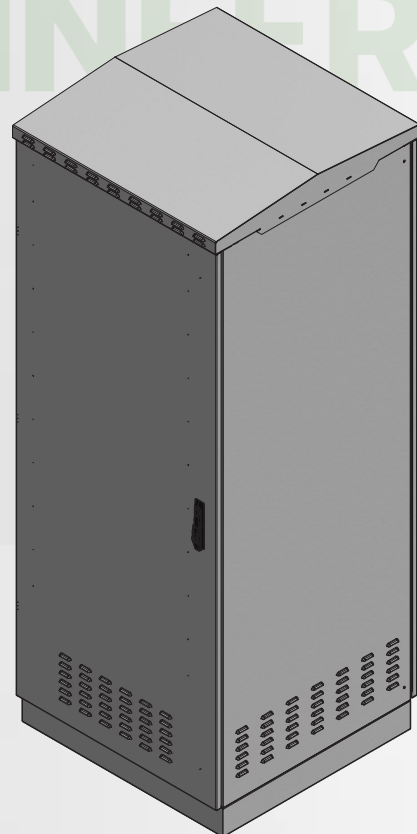

Front Isometric View

FROG ENGINEERING



FROG ENGINEERING

IP65 H-41U 800x800

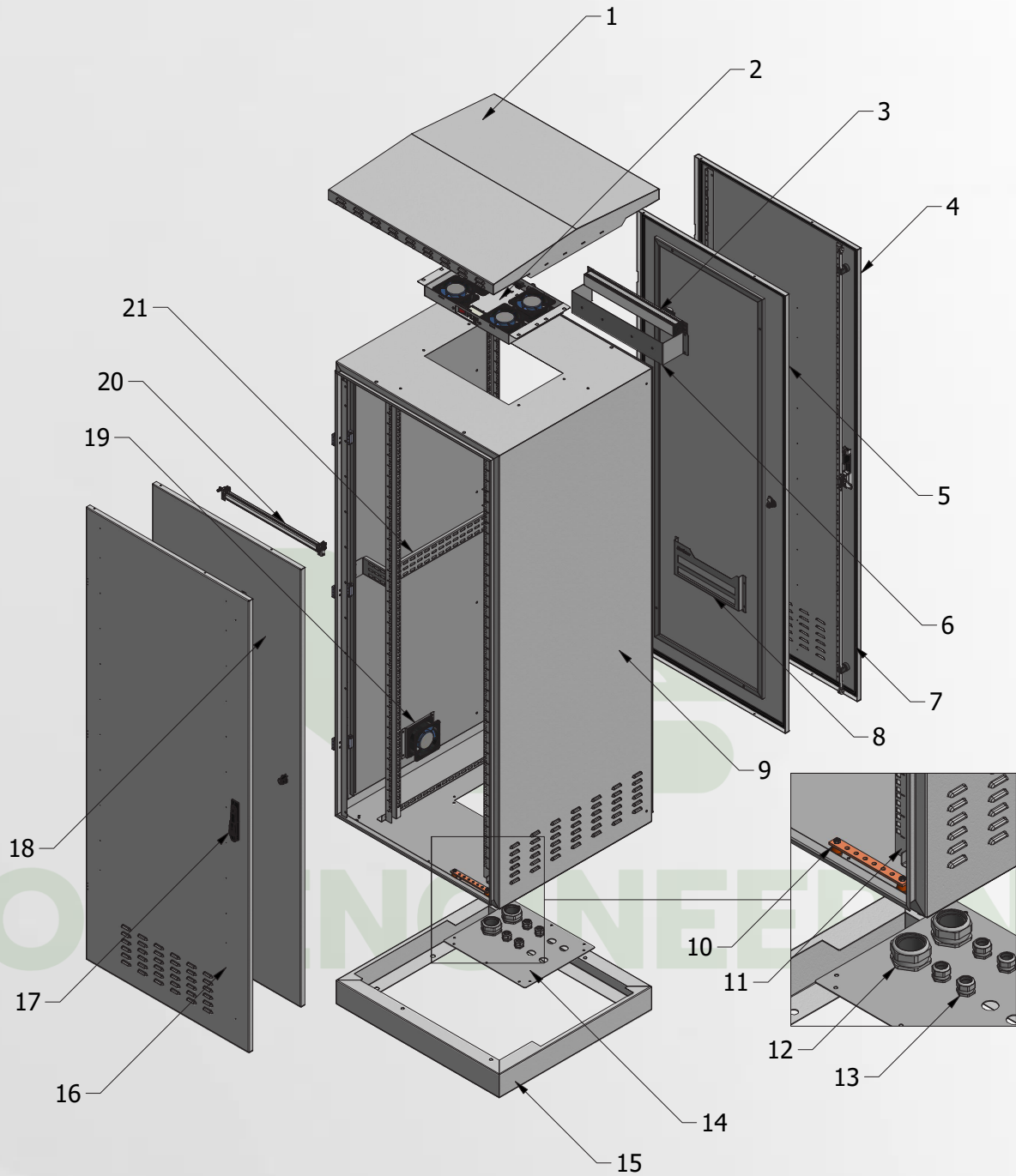

PART LIST

NO	PART NAME	NO	PART NAME
1	Top Cover	12	PG48 Gland
2	Fan Module	13	PG21 Gland
3	PDU	14	Cable Gland Module
4	Rear Door	15	Plinth
5	Inner Rear Door	16	Front Door
6	DIN Rail Mounting Plate	17	Front Door Locking Mechanism
7	Gasket	18	Inner Front Door
8	Project Pocket	19	Fan Unit
9	Body	20	LED Lighting
10	Earthing Bar	21	Horizontal Support Bar
11	19" Device Mounting Rail		