

## Datasheet and Installation guide GP01-H25JF4 enclosure

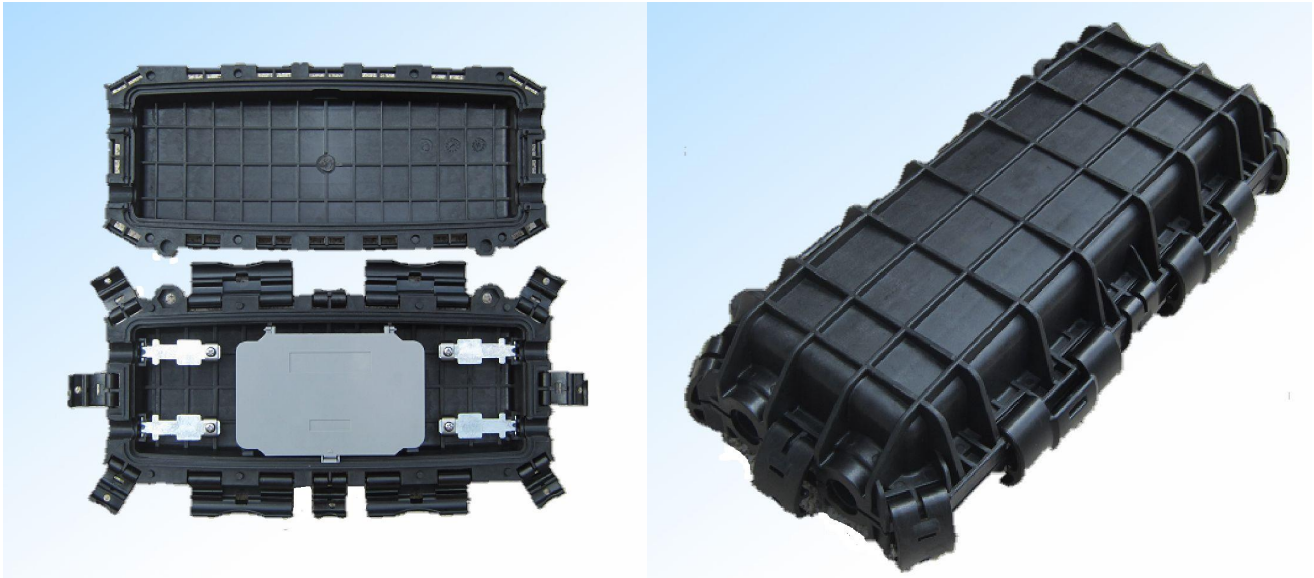







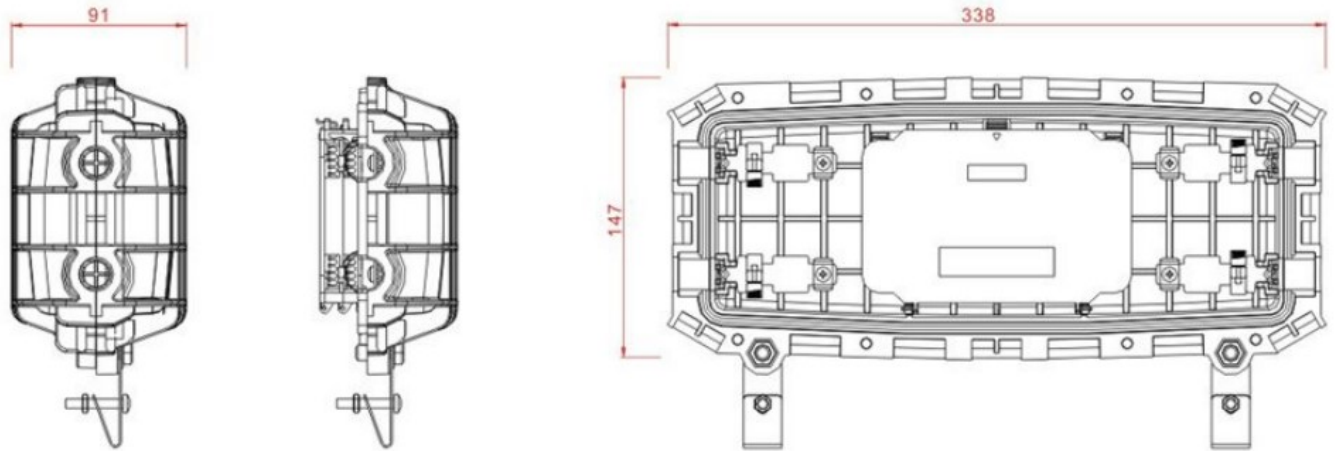



It can be used to connect and branch fibers in aerial locations applications. The case body is made from high-intensity engineering plastics and shaped by mould injection under high pressures. Adding anti-UV corrosive-resistance, anti-thunderstruck material with long service. Splice tray with optical fiber radius of curvature  $\geq 40$  mm. Low optical loss.

<b>Model</b>	<b>GP01-H25JF4-48</b>
Material	PP
Dimension	338*147*91 mm
Applicable Cable Dia.	6-16 mm
Outlet and Inlet	2 Inlets and 2 outlets
Max. Capacity of Splice Tray	24core (single fiber)
Max Capacity	48core
Sealing Method	Mechanical Sealing with Rubber ring
Application Environment	Aerial

## 1. EXTERIOR STRUCTURE DIAGRAM



## 2. ACCESSORIES LIST

Item	Picture	Amount	Item	Picture	Amount
Entry port block		Total 2 pcs	Hose clamp For cable fixing		Total 4 pcs
Optic joints protective tubes		Max. 48 pcs	PE transparent tube for bare fibers		1 pc
Abrasive tape		1 pc	Nylon tie		4 pcs
Number tube		Based on splice capacity	Shield continuity wire		1 pc
Aerial mounting kits		1 set	Sealing ring		1 set
Cleaning tissue		1 pc			

### 3. INSTALLATION GUIDE:

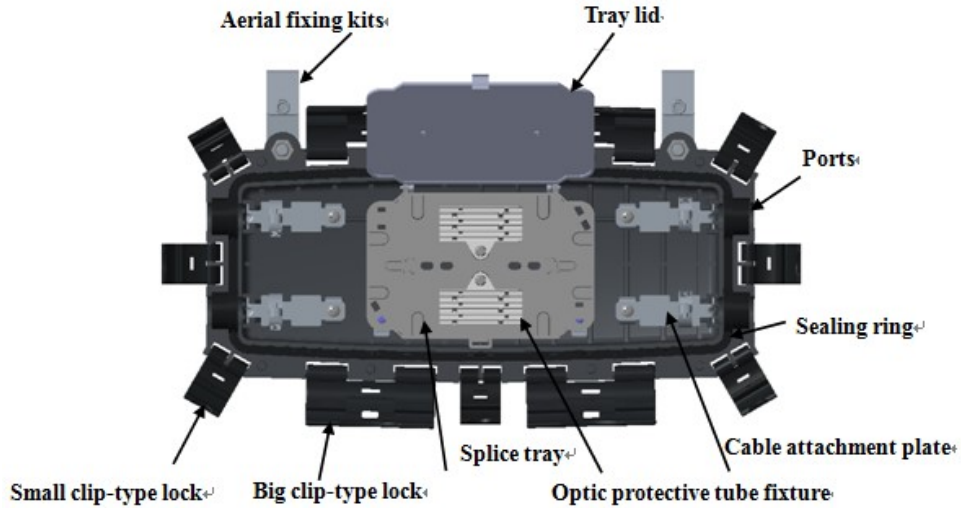

Assembly Steps	Working Contents	Notes
5.1 Opening enclosure	1. Clean the working area. Locate the positions and layout the cables to be installed. 2. Count the accessories. 3. Open the closure by using the special wrench to loosen the screws and the fixing screws on the 2 corners (hook fix place).  <b>See Picture 1</b>	Keep away from dust and water. In bad weather, the use of a tent might be required.

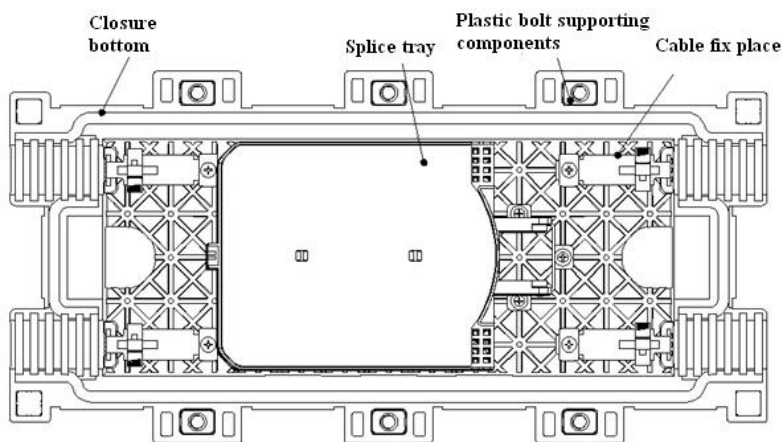

Picture 1

Assembly Steps	Working Contents	Notes
5.2 Measure the cable fixing and stripping length	1. 75mm cable length: fix on the entry port and cable clamp. 2. 2030mm bare cable length: used to store and splicing after stripped. 3. 430mm bare cable protect tube: Cable to store in the enclosure. 4. 1600mm optic fiber length: stripped cable to be stores in the splice tray after splicing. <p style="text-align: center;"><b>See Picture 2</b></p>	1. Keep enough cable length. 2. Carefully measure the strip length. 3. Workers can personally decide the stripped cable length to accommodate variations.

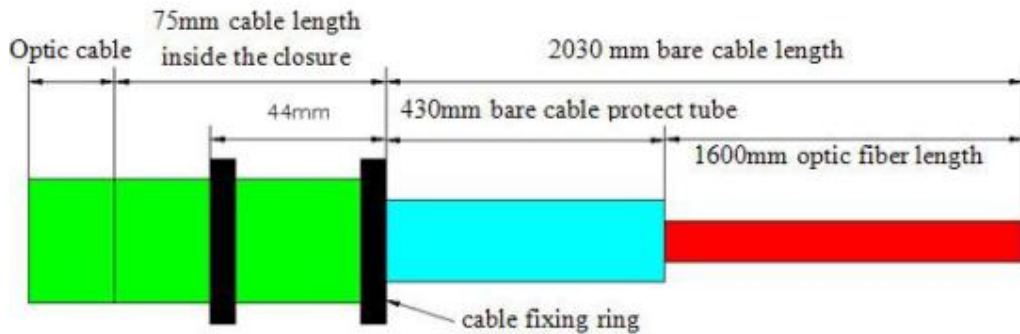

**Picture 2**

Assembly Steps	Working Contents	Notes
5.3 Strip the cable jacket and fiber protective tube	1. There are maximum 4, 6 or 8 cable entry ports on these enclosures. Users can choose the number of ports in use. 2. Available Cable Dimension. A. Cable max. Dia. $\Phi$ 18mm B. Cable max. Dia. $\Phi$ 14mm C. Cable max. Dia. $\Phi$ 12mm Choose the right port corresponding with the cable dia. Use the sealing gummed tape to adjust the cable dia. when cable dia. is too small. 3. Put the cable ring in the place shown in picture 2. Clean the cable and put it through the rings. Wrap around the cable between the fixing rings with sealing gummed tape to keep the seal inside the enclosure. 4. Use the pipe cutter and cable cutter to open the sheath of the cable. The length refers to picture 2.	Care not to break fiber cables.

Assembly Step	Working Contents	Notes
5.4 Separate the cable fiber and preparing the cable fixing work	<p>Remove the filler inside the cable, separate the cable core cable inner tube and clean it. Then put on the bare cable protective tube. And wrap two layers of PVC tape around the joints.</p> <p>2. Tighten the stainless-steel clamp on the entry port, make sure the cable attaches tightly to it.</p> <p>—、Keep 40mm-50mm length of the cable strengthen member.</p> <p>3. Remove the cable filler and clean the PVC tape-rolled cable. Remove the cable filler and clean the PVC tape-rolled cable. Wind the fibers in about 100mm dia. loops and temporary fix it.</p> <p style="text-align: center;"><b>See Picture 3</b></p>	<p>1. Sand the cable with Abrasive strip and clean it before wrapping the PVC tape around the cable.</p> <p>2. Use wire pliers to cut the cable steel core.</p>

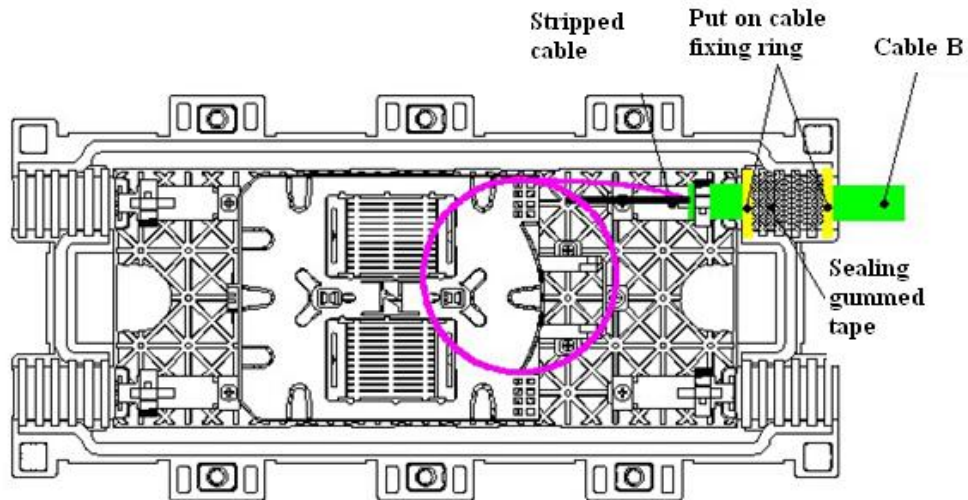

Picture 3

Assembly Steps	Working Contents	Notes
5.5 Fix strengthen core and fiber	<p>1. Thread the fiber strengthen core into the fixed bolt, adjust the distance, bend the strengthen core bending steel clamp &gt; 90°, leaving 1cm length, and cut the excess steel core, then tighten the screw.</p> <p style="text-align: center;"><b>See pic.4</b></p>	

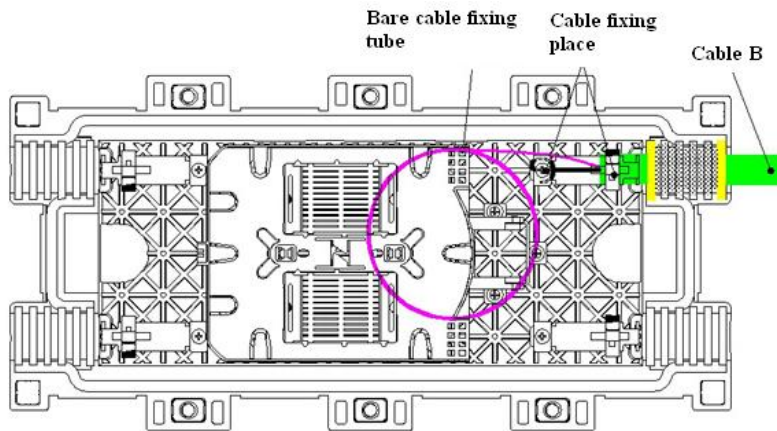

Pciture 4

Assembly Steps	Working Contents	Notes
5.6 fiber splicing	Pls refer to the fusion splicer guidelines	Before splicing, plan the work and make sure there are not twists or abnormal bents
5.7 Install the fiber splice protective tube and fiber storage	<ol style="list-style-type: none"> <li>1. Circle the fiber with protective tube into fiber rings, diameter &gt; 100mm or similar. Tie the bare cable protective tube end at the entry of the splice tray. Splicing should begin in the bottom of splice tray.</li> <li>2. After fiber splicing, normally the first lap coiled in the outermost disk, the other fiber coiled into a circle of no less than 80mm in diameter, and put together into fiber tray with the protective tube (firstly, to fix the fiber optic protection tube on the slot, and then enlarge diameter of the fiber ring to the appropriate location).</li> </ol> <p style="text-align: center;"><b>See pic.5</b></p>	Notice sections that might be twisted or bent

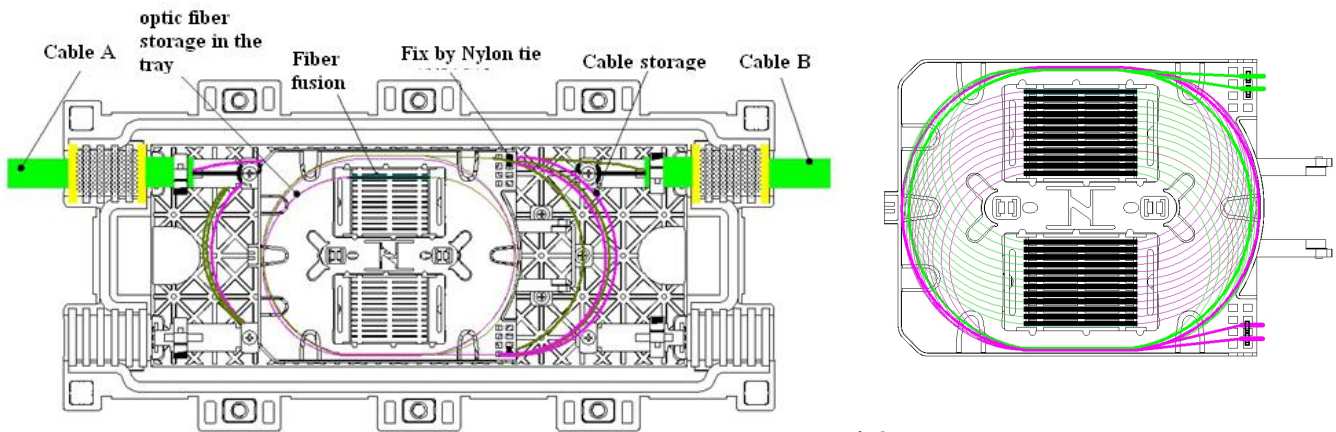

**Picture 5**

Assembly Steps	Working Contents	Notes
5.8 Check the sealing member and the process requirements	1.Splice tray installation should be neat, fiber bend radius should meet the requirements. 2.Tighten the internal fastener 3.Unused cable entry ports should be plugged with the original end cap, inside recessed part of end cap should be wrapped with sealing tape. 4.The sealing tape should be used in reasonable amounts. 5.The sealing tape should be flat on the corresponding slot.  <p style="text-align: center;"><b>See pic.6</b></p>	

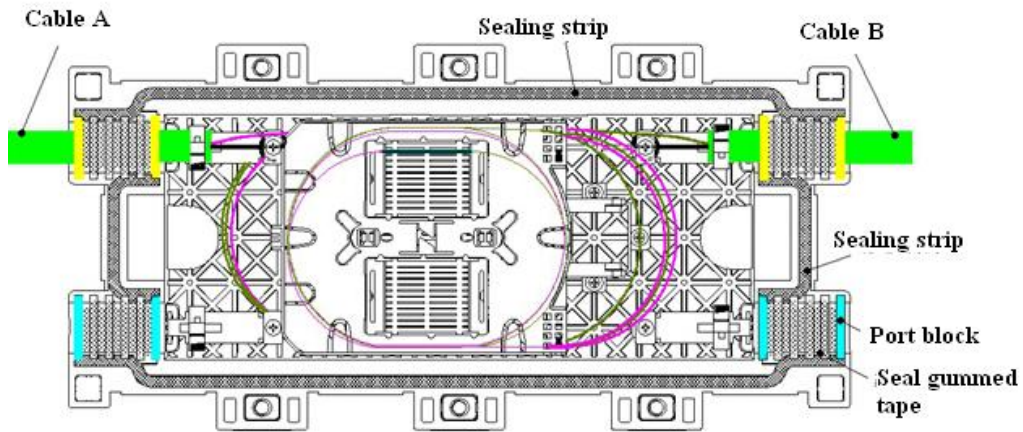

Picture 6



Assembly Steps	Working Contents	Notes
5.9 Outer shell installation	<p>Optional Methods:</p> <p>Type one:</p> <ol style="list-style-type: none"> <li>Cover up the closure upper sheath and base</li> <li>Use Allen key to tighten screws following the order as in pic. 7</li> </ol> <p>For aerial installation, Use M8*35mm bolt to fix 2 pcs of plastic bolt supportings and nut supporting brackets on the closure. At meantime, use two M5*30mm stainless screw to fix the closure in appropriate position.</p> <p>Type two:</p> <ol style="list-style-type: none"> <li>Cover up the closure upper sheath and base</li> <li>According to pic. 8 marked number, use special wrench to tighten M8*30mm stainless steel screw.</li> <li>For aerial installation, use two M5*30mm stainless screw to fix the closure in appropriate position.</li> </ol>	<p>Clean outer shell, tighten the screws orderly.</p> <p>Then re-tighten screws in order.</p>

Assembly Steps	Working Contents	Notes
5.10 Reopen the enclosure	<ol style="list-style-type: none"> <li>Open the fiber closure: remove the set screw on the shell and two angles by special wrench, upturning the plastic clip.</li> <li>Using shell set screw, uniform screwing the upper cover hole, separate the upper cover and the base.</li> <li>Clean the sealing rubber strip.</li> <li>Then according 5.2-5.9 steps to splicing the fiber</li> </ol>	