

Datasheet and Installation guide GP01-H54JF4 enclosure

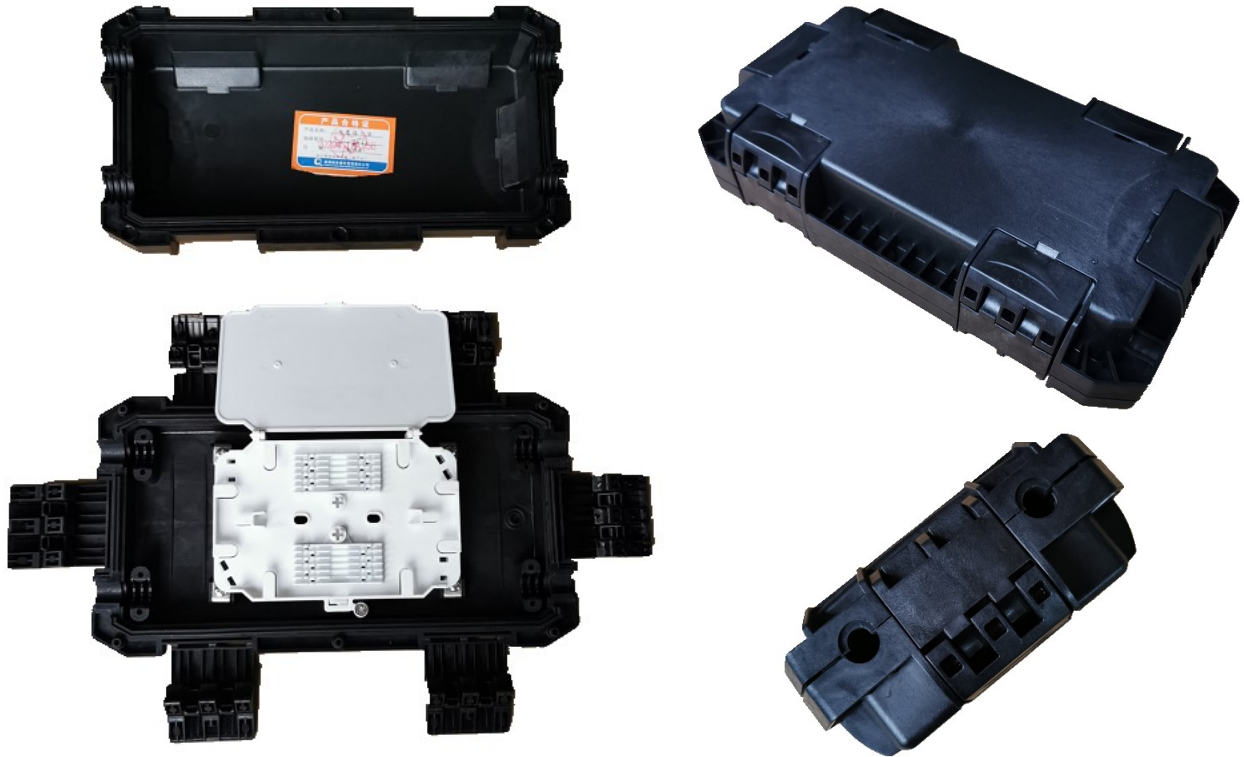

In-line optic splice closure is specially designed to splice and protect fiber joints of all type of optic cable with dimension $\leq 12\text{mm}$. It is mainly used to connect and branch optic cables in overhead, pipeline or manhole applications. Adopt high-intensity engineering plastics and formed by plastic injection mold under high pressures. Adding anti-UV, corrosive-resistance, aging-resistance elements, to be with long durability. Reopenable mechanical sealing system, simple and reasonable inner structure, easy installation, is a reliable option for communication network construction.

Spec.	Size mm	Tray Capacity	Max. Splice capacity	Ports number & available cable dia.	Raw material
GP01-H54JF4-24~48	281.6*151.6*70.5	24F/Tray	48F	2 inlets and 2 outlets for cable dia. Φ 6-12mm	Closure: Modified P.P. +GF Tray: ABS Metal: Stainless Steel

Technical Parameter:

- IP: 67
- Working Temperature: -25 degrees centigrade~+60 degrees centigrade
- Fiber Curvature Radius $\geq 35\text{mm}$
- Additional Loss after coiling in the enclosure: $\leq 0.01\text{dB}$
- Bare fiber storage length in the splice tray: $\geq 1\text{m}$
- Anti-Lateral pressure: $\geq 2000\text{N}/10\text{cm}$
- Impact Resistance: $\geq 20\text{N.m}$

2. Exterior Structure Diagram.

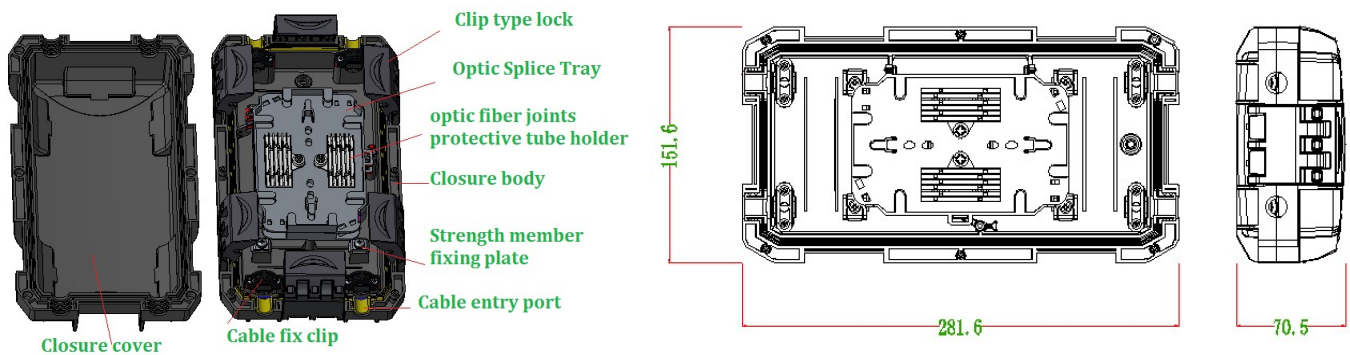

3. Packing info.

Inner carton	Size	Weight	Outer carton	Size	Weight
1 pc product	32.5*20*10.5cm	0.95kg	10 pcs products	40.5*53.5*37cm	10.5kg

4. Accessories List

Item	Amount	Picture	Item	Amount	Picture
Closure body and cover	1 set		Splice tray	Based on splice capacity	
Sealing Ring	1		Silicon gel strip	2	
Aerial mount kits	1 set		Optic fiber joints protective tubes	Based on splice capacity	
Cable fixing clip	1 sets		Transparent tube	Based on splice capacity	
Abrasive tape	1 pc		Nylon tie	4pcs	
Number sticker	1 pc		Port blocker	2pcs	

5. Installation Guidance

1. Remove the sheath of the optic cable. Spare 1.1-1.6m bare fibers and keep 30-50mm length of the strength member wire. Bend the wire $> 90^\circ$. Put the bare fibers through the transparent tube. Use PVC tape to wrap the joint places of the cable and the transparent tubes.



2. Put the silicon gel strip on the cable and fix it in the cable entry port.

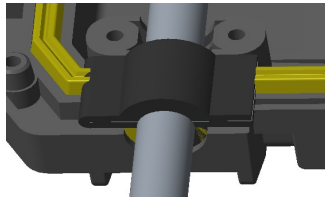

3. Put on the cable fixing clips and tighten the screws to fix the cable and strength member wires.

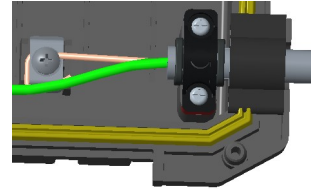

4. Wind the transparent tube protected fibers in fiber rings with a dia. $> 100\text{mm}$

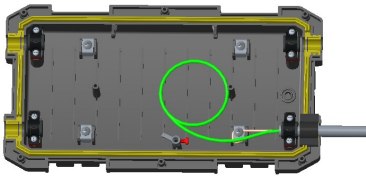

5. Guide and coil the optic fibers into the splice tray. Fusion the fiber joints and fix the optic protective tubes in the tray. Adjust the fiber rings, then put the tray cover on the top tray.

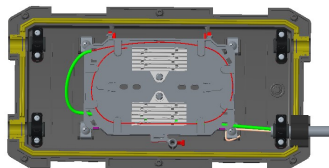

6. Wrap the port blocker with gel strip and put in the unused ports. Put on the closure cover to close the closure.

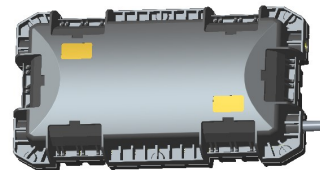

7. Close the clip type locks and cleaning the closure surface. Recheck the sealing of the closure.

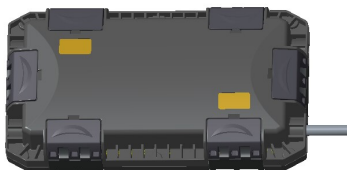

8. Choose the suitable mounting kits. And fix it as required.

