



FROG ENGINEERING

Pole Type Cabinet H-633 W-600 D-400

OVERVIEW





FROG ENGINEERING

Pole Type Cabinet H-633 W-600 D-400

OVERVIEW



FROG ENGINEERING

Technical Details

Features

IP66 Protection
Fan Module
19" Compatibility
PG Gland Unit
Mounting Bracket
Extra Wall

Dimensions

Width : 600 mm
Height : 633.6 mm
Depth : 400 mm

Material

1.5 mm Galvanized Steel
(TS 914 EN ISO1461:2001)

Appearance

Finish Surface : Powder Coating
Color : RAL7035

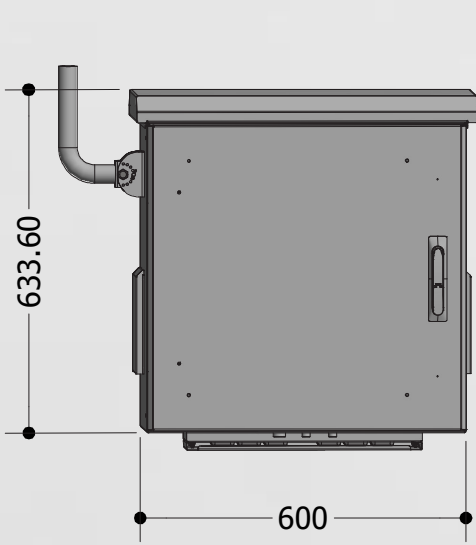

Front View

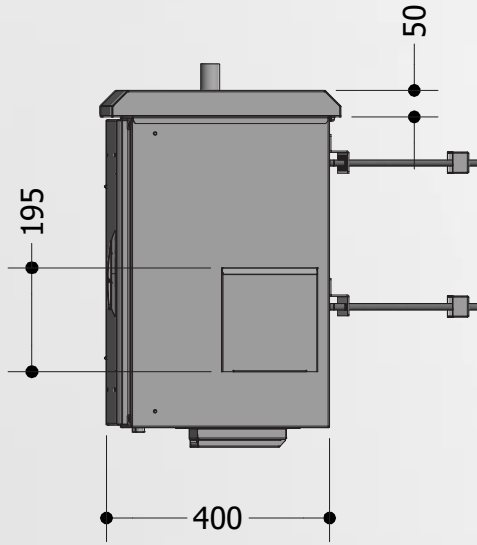

Side View

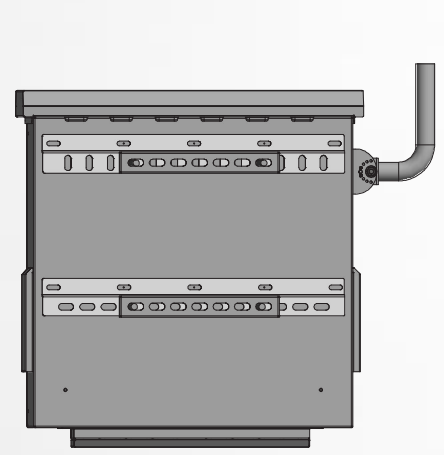

Rear View

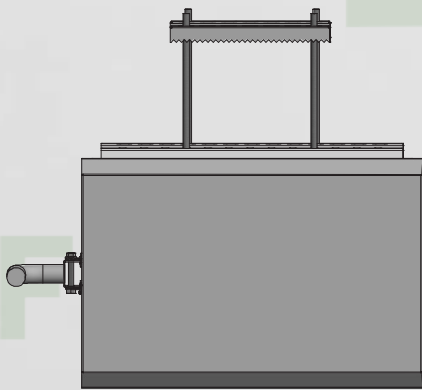

Top View

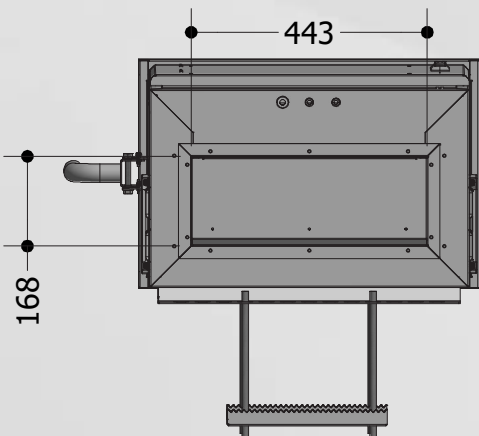

Bottom View

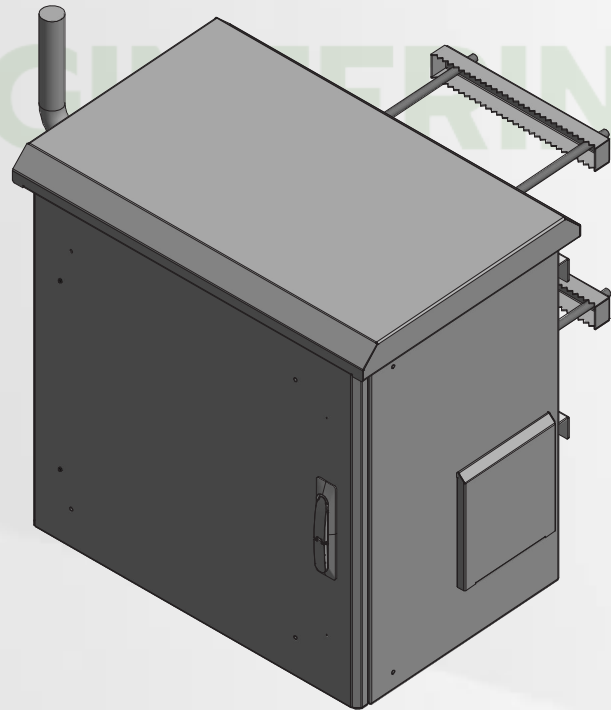

Front Isometric View

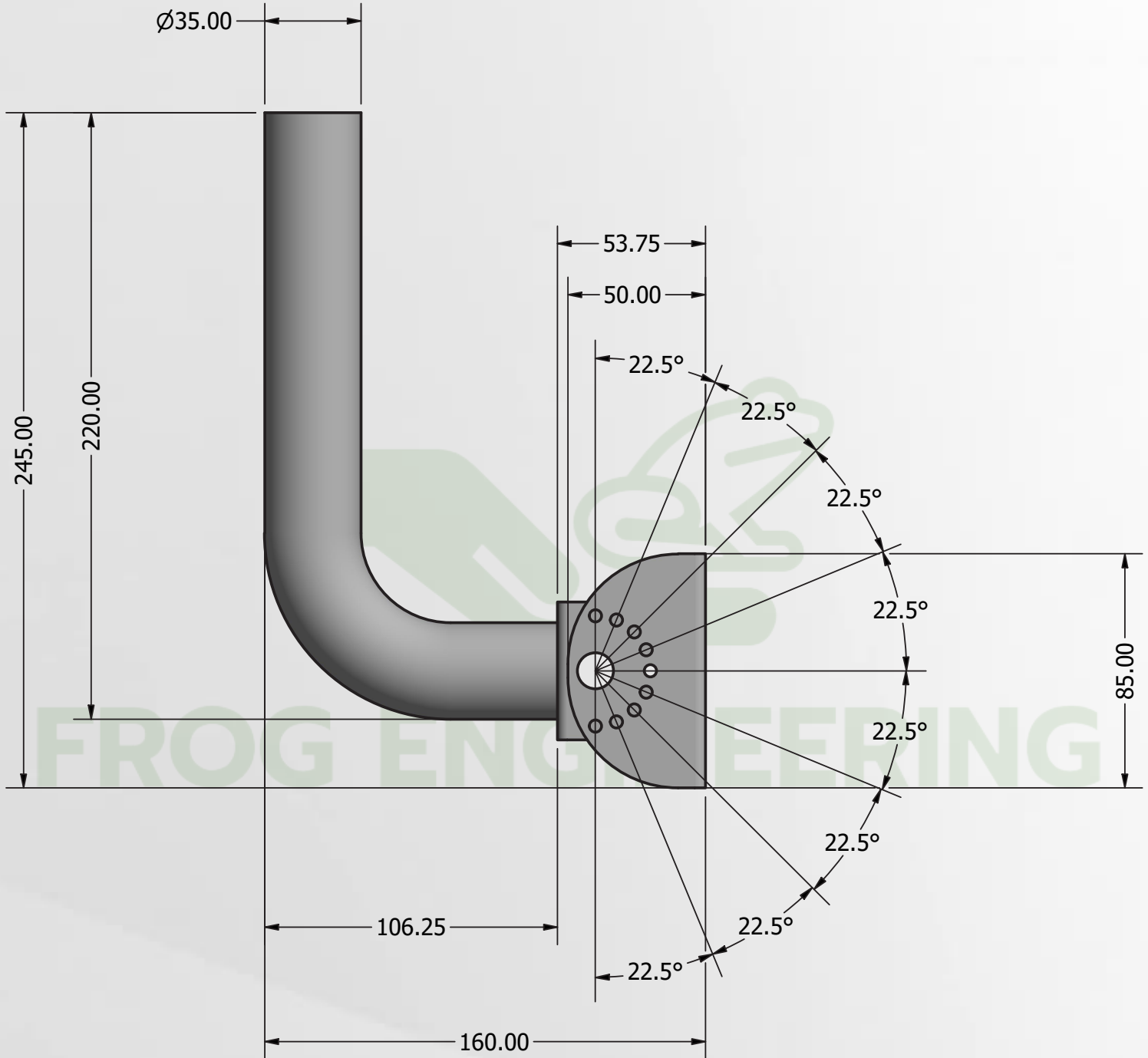



FROG ENGINEERING

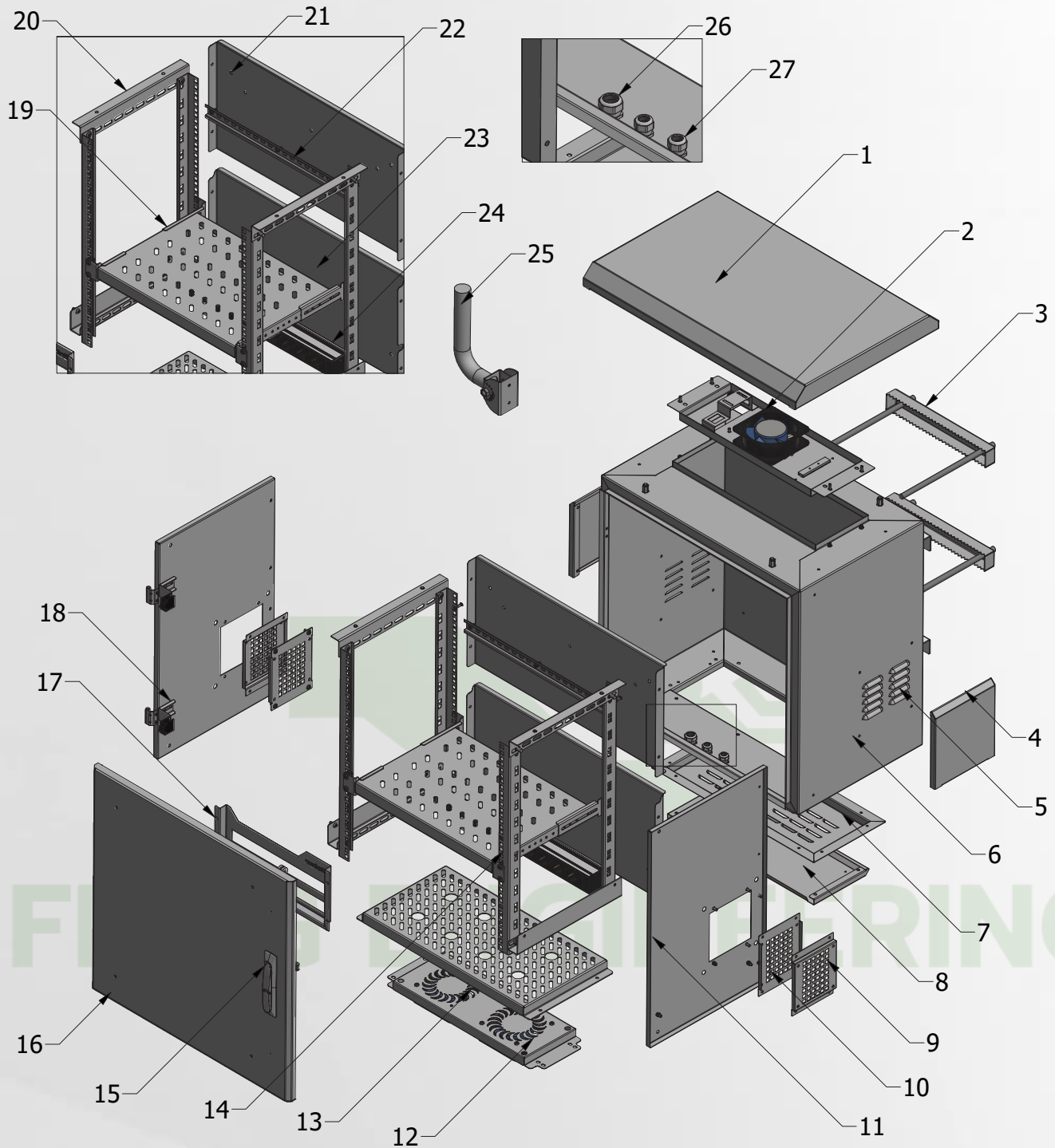

COMPONENT LIST

NO	PART NAME	NO	PART NAME	NO	PART NAME
1	Top Cover	10	Fan Filter (Inner)	19	Perforated Shelf
2	Top Fan Unit	11	Inner Side Wall	20	Horizontal Support Bar
3	Cabinet Pole Mounting Kit	12	Fan Module	21	Inner Rear Wall (Upper)
4	Ventilation Cover	13	Bottom Fan Cover (Inner)	22	DIN Rail
5	Ventilation	14	19" Device Mounting Rail	23	Inner Rear Wall (Lower)
6	Cabinet Body	15	Front Door Locking Mechanism	24	6 Way PDU
7	Fan Cover	16	Front Door	25	Antenna Mounting Bracket
8	Extra Fan Cover	17	Project Pocket	26	PG16 Gland
9	Fan Filter (Outer)	18	Door Switch	27	PG9 Gland (2 pcs)



A: Steady-State Thermal
Figure
Type: Temperature
Unit: °C
Time: 1 s
7/29/2021 06:00

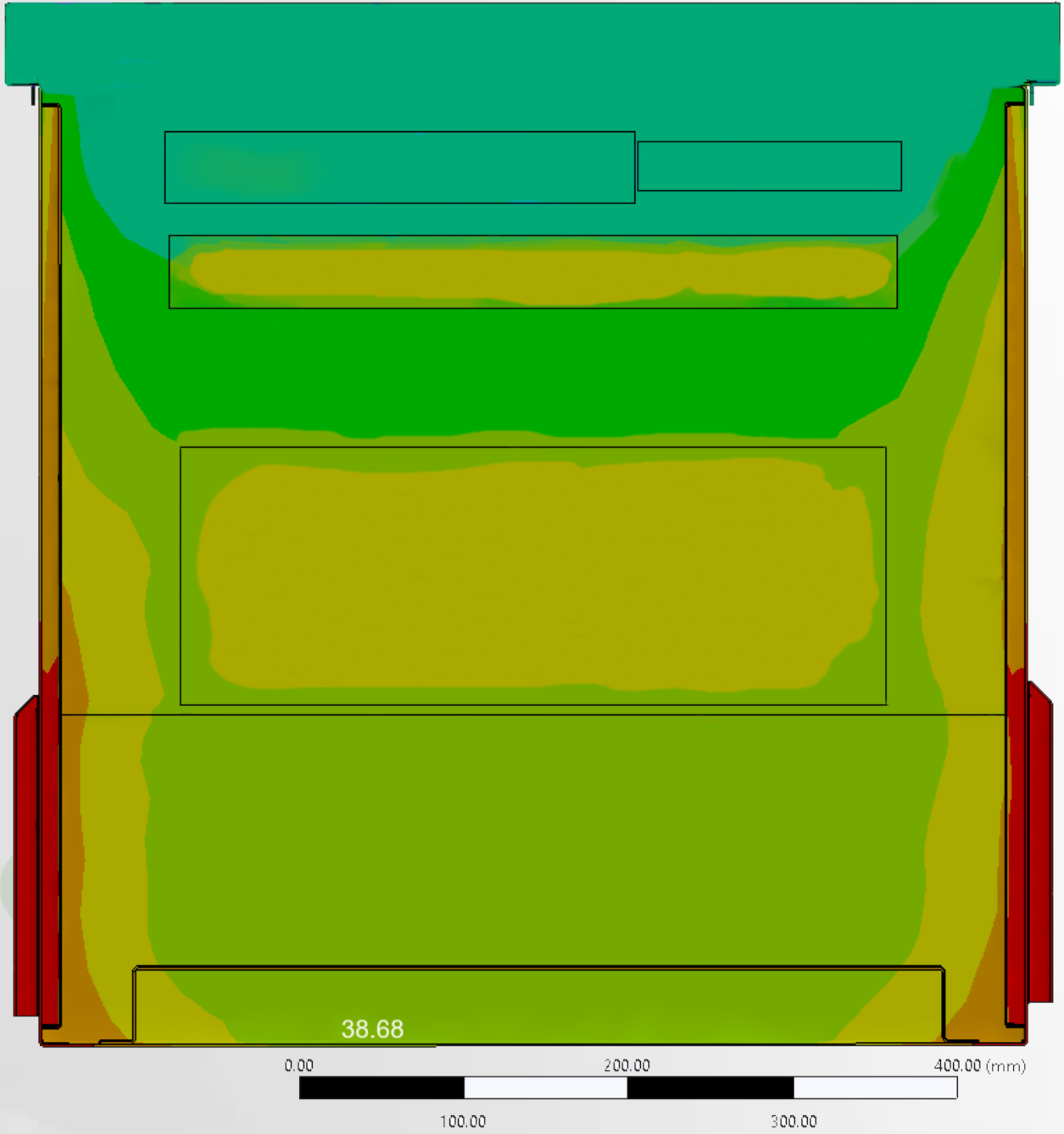
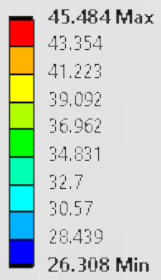

Analysis Data : Outdoor temperature is determined as 45 °C, cabin interior remains below 40 °C